

## 1. Foreword

All information and warnings about 3 phase controlled reactive power controller, VARko-3xx\*, are given in this User's Manual. Please for your power network's and your own safety, read this manual carefully before commissioning the system.

## 2. Warnings:



- 1- The connection, operation and parameter settings of device must be done by authorised technical service staff. Also, system checks must be done by this person when necessary.
  - 2- Since compensation is a complex process, subscribers are advised to keep the system tracking by contracted service staff.
  - 3- Please do not open or do not let others open the device. There are no user serviceable parts inside.
  - 4- Before making the connections to device's terminals, please be sure that there is no voltage across the cables or terminals. Also be sure that the panel is de-energised.
  - 5- Please do not use the device for purposes other than compensation.
  - 6- Please fix the device to electric panel with apparatuses supplied.
  - 7- Please press the buttons only by your fingers, do not press it with any other objects.
  - 8- Before cleaning the device, please be sure that it is de-energised and use only dry tissue-paper to clean it. Water or any other chemicals used for cleaning may harm the device.
  - 9- Before installing the device, please be sure that the terminal connections are made exactly the same as in the connection diagram and avoid any connection problems, such as loose connections or contact of different cables.
  - 10- For each capacitor bank on the compensation system, please prefer contactors with suitable discharge resistors considering the bank power.
  - 11- Please consider total currents drawn by the inductors of contactors while choosing the common contact line, line 'C', fuse value. When contactors with high inductor currents are chosen, for protecting the contact outputs of the device, auxiliary relay must be used.
- \* The statement VARko-3xx covers both 8 and 12 steps models of the device.

### Installation Instructions :

1. A hole with 140 mm x 140 mm must be needed on the panel for device installation
2. Remove the fixing apparatus before installing the device
3. Place the device in the prepared hole from the front side.
4. Use the fixing apparatus to fix the device from the back side to the panel.

#### CAUTION:

Leave at least 50mm space between the back side of the device and the internal wall of the panel for the airing purpose

Panel Hole Dimensions

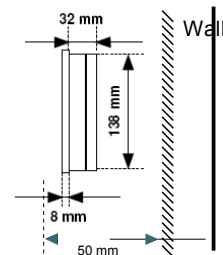
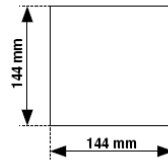
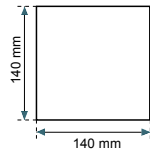

## 3. General Information

When traditional type reactive power controllers are used, specially for unbalanced 3 phase systems, compensation process gets more complex and for some of the situations it is a nightmare. To overcome this problem, experience, knowledge and scientific background are put together with the help of high technology and VARko-3xx, 3 phase evaluative reactive power controller, is developed by KAEL Elektronik.

The most important properties of VARko-3xx that make it different from traditional type controllers are;

- 1- Measuring current and voltage samples from all 3 phases, calculating active and reactive powers and storing consumed energies,
- 2- Instead of reaching to target  $\cos\Phi$  value, compensating the system as much as close to real axis between the capacitive and inductive bound values. (Bound values can be changed by the user when desired),
- 3- Automatic C/k calculation,
- 4- Automatic learning and monitoring of capacitor bank powers (capacitor bank powers can be set by the user when desired. Device also detects any false setting and corrects it by its own as it operates),
- 5- Dynamically adjusting of normal region boundaries and capacitor switching on&off times with respect to consumed reactive/active percentage,
- 6- Extending capacitor bank power life by storing switching on&off times separately for each bank,
- 7- Automatic learning of current transformer polarities even if (k,l) is connected in reverse direction,
- 8- Calculating current reactive power value and directly switching on or off the most suitable group instead of sequential switching,
- 9- Making system tracking and fault detection easier with many hand alarms,
- 10- Compensation with respect to resultant power factor ( $\Sigma \cos\Phi$ ) calculated as the vectorial sum of three phase powers.

### 3.1 Operating Principles

When the device is energised, it checks first the voltage values. Then, it detects current transformer polarities even if connected in reverse direction. The direction of system's reactive power is calculated through resultant reactive power and resultant power factor. Compensation starts for pulling the system into 'normal region'. Device measures active, inductive (+Q) and capacitive (-Q) powers for each phase and stores the consumed energies. After mathematical calculations, inductive and capacitive percentage values of the system are calculated continuously and the system is kept under control.

Capacitor switching on&off times are calculated separately for each bank. When necessary, the appropriate bank is directly switched if its time is up. Since the Switching Time Values and Normal Region Boundaries are related to consumed energies, they change between the max and min values proportional to percentage energies. During the operation, every capacitor bank's power is calculated when it is switched. Therefore, any change of the capacitor bank's power is detected and stored. Instead of sequential switching of capacitors, the most suitable bank is directly switched. VARko-3xx contains 9 alarms from AL01 to AL09 and 1 alarm relay output to warn and inform the user. Alarms are; over voltage, under voltage, over current, over compensation, under compensation, system fault, capacitor bank fault, phase failure and over temperature. If desired, as much as alarms can be disabled by the user. Device also measures the panel temperature and energises the fan relay when temperature exceeds adjusted fan relay limit (adjusted separately from temperature alarm). 4 different operating modes of the device exist. When the device is energised for the first time, it starts from Mod 1. The device can be restricted to Mode1 or Mode 2 if desired. Otherwise it promotes to full automatic mode, Mode 3, after learning/setting all capacitor bank values.

#### MOD 0 :

This is the manual mode. In this mode, device does not switch the banks by its own. It is accessed by pressing down the set button 3 seconds in Main Menu. In this mode, both mode leds are off, 'El' text and current display value are continuously interchanged. By pressing down the up button, capacitors are sequentially switched on and by the down button switched off. During the process, the last parameter accessed in the main menu is displayed on the display. By pressing down the set button, system returns to main menu. This mode is used only for testing the system.

#### MOD 1 :

When the device is energised for the first time, it start in Mode 1. Since it knows none of the capacitor bank powers, Normal Region is dynamically calculated through penalty boundaries, consumed inductive and capacitive energies. Capacitor switching is done as 'first-in-first-out'. Device tries to calculate each bank's power after every switching. When the device learns 1<sup>st</sup> bank's power by its own or it is set by Atrf (Current transformer ratio) and C-01 parameters under Advanced Menu-Cset, it skips Mode 1.

#### MOD 2 :

If the device learns 1<sup>st</sup> bank's power by its own or it is set by the user, system operates in MODE 2. In this mode, additionally to Mode 1, since the 1<sup>st</sup> bank's power is known, C/k is automatically calculated. Except this, it is identical to Mode 1. When the device learns power values of rest of the banks by its own or they are set by Atrf (Current transformer ratio) and C-01, C-02 ... C-12 parameters under Advanced Menu-Cset, it skips Mode 2.

#### MOD 3 :

If the device has learned all the capacitor banks' powers, it operates in Mode 3. Learning process can be done fully automatically by the device or it can be done by the user by setting Atrf (Current transformer ratio) and C-01, C-02 ... C-12 parameters under Advanced Menu-Cset, just for gaining time. Normal Region is dynamically calculated through penalty boundaries, consumed inductive and capacitive energies.

Since in this mode device has all necessary information for compensation, it directly switches the necessary bank instead of sequentially switching with 'first-in-first-out' algorithm. Thus, in this mode, switching logic completely changes in a manner to find appropriate bank to keep the system in normal region and response time to changes in load dramatically decreases. This algorithm gives VARko the ability of keeping system as close as possible to real axis and adapting itself very fast to load characteristics. Once the device has advanced to Mode 3, it will operate in this mode even if it is de-energised and energised again in the future.

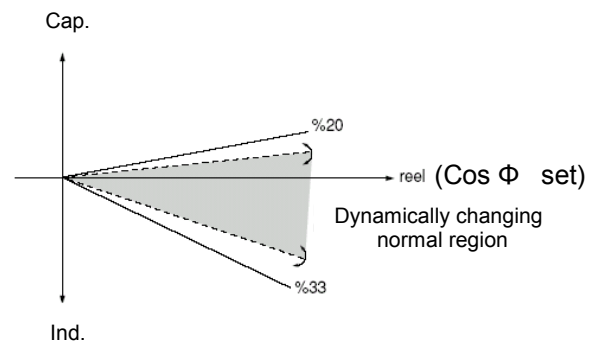

### 3.2 Measuring Parameters

VARko-3xx gives user the ability of monitoring the following parameters;

cosΦ of Phase R

cosΦ of Phase S

cosΦ of Phase T

CosΦ that is calculated from vectorial sum 3 phase power values,

Instantaneous percentage value of system (reactive power / active power) respect to vectorial sum of 3 phases

Current values of phases R,S,T

Voltage values of phases R,S,T

Power of each capacitor bank (in case of correctly setting of current transformer ratio)

Panel temperature(°C)

## 4.FRONT PANEL (Display and LED Functions)

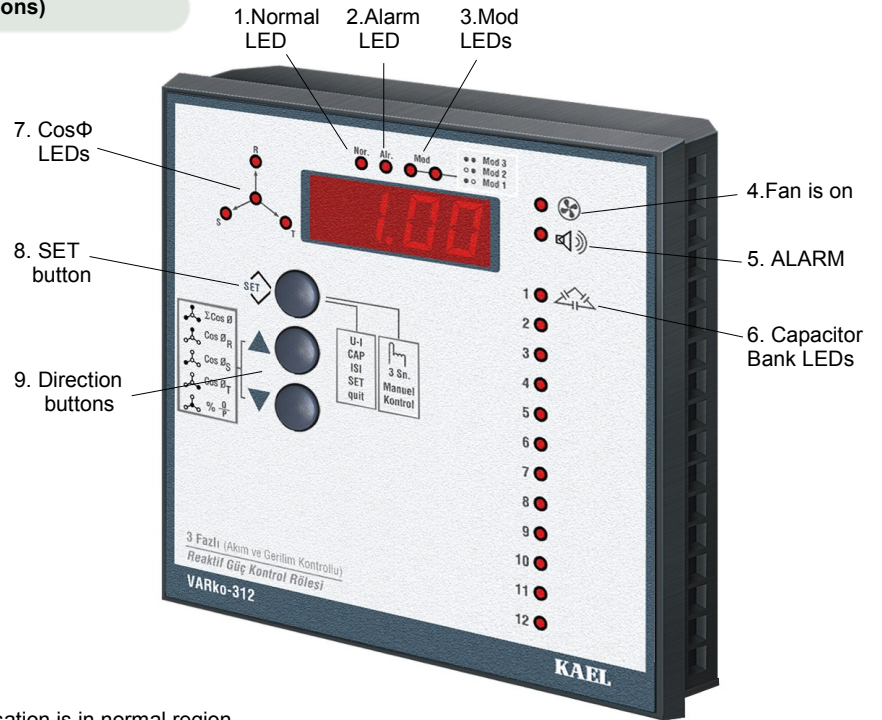

- 1. Normal LED** :Indicates that compensation is in normal region.
- 2. Alarm LED** :If there is any alarm, the LED is on. When the alarm situation disappears, LED is turned off.
- 3. Mod LEDs** : Indicates the operating mode of the device;
  - Mod 0: Manual operating mode.
  - Mod 1: Traditional operating mode.
  - Mod 2: C/k calculation respect to 1<sup>st</sup> banks power.
  - Mod 3: Fully automatic operating mode.
- 4. Fan Is On** : When inner panel temperature exceeds set value, fan relay energizes and Fan On LED is turned on.



- 5. ALARM** :In the presence of any alarm, alarm relay is energized for 1 minute, Alarm Output LED and Alarm LED are turned on together. After 1 minute, relay is de-energized, Alarm Output LED is turned on. On the other hand, Alarm LED stays on till the problem disappears.



- 6.Capacitor Bank LEDs** : It shows the switched on capacitor banks.



- 7. CosΦ Leds** : Desired values to watch can be accessed in the Main Menu using the direction buttons. In default case, it displays Resultant Power Factor of 3 phase system. When any other value is chosen, if non of buttons is pressed for 1 minute, device returns to default state.

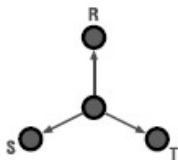

- : $\Sigma \cos\Phi$  , resultant power factor of 3 phase system
- :  $\cos\Phi_R$  , power factor of phase R
- :  $\cos\Phi_S$  , power factor of phase S
- :  $\cos\Phi_T$  , power factor of phase T
- : instantaneous reactive power/active power percentage of 3 phase system.

- 8. Set Button** : It is used to access to User Menu and Advanced Menu. Also it gives the permission of parameter changes in the menus. Short pressing (less than 1s) brings to User Menu. At power up time, long time press (at least 3s), devices is brought to advanced menu.



- 9. Direction Buttons** : In the Main Menu, desired parameters can be accessed using these buttons. In other menus, used to browse menus and changing parameter values in setting screen.

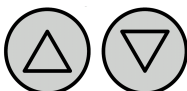

## 5. MENUS and BUTTON FUNCTIONS

Accessing to menus of VARko-3xx using the buttons is very easy. Using the direction buttons, menus can be browsed in two directions. When you reach the end of the menu, you continue to circular movement. When hold down the directions key, travel speed is increased and you can access to desired location faster. You can enter to desired menu level by pressing down the Set button. Also in the parameter adjustment menus, you can change the values by direction buttons, keep circular movement when you reach to limit values and can store the desired value by pressing down the Set button. In the User Menu, when no button is pressed for 1 minute, device goes back to Main Menu. In Advanced Menu, when no button is pressed for 4 minutes, devices resets itself

### 5.1 Main Menu

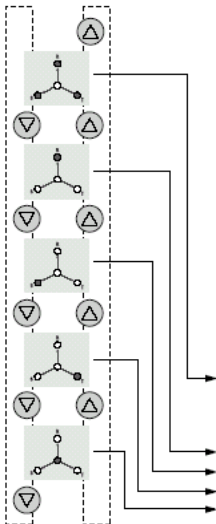

It is the default menu stage that is active during device operation. Every time the device is energized, it starts to operation by showing the resultant power factor. Power factors of each phase and instantaneous reactive power/active power % of the system can also be monitored separately using the direction buttons. When any of the parameters is being monitored, if non of the buttons is not pressed for 1 minute, device returns to default state, resultant power factor display. The position of monitored value can be tracked from the Status LEDs. When the displayed value has no sign, this means the value is Inductive and when it is negative, '-', signed, this means value is capacitive. Movement in Main Menu using the direction buttons is described on left.

- $\Sigma \cos\Phi$  : The resultant power factor value of 3 phase system. It is the most important parameter to be watched for tracking the compensation of system.
- $\cos\Phi R$  : Power Factor of phase R
- $\cos\Phi S$  : Power Factor of phase S
- $\cos\Phi T$  : Power Factor of phase T
- reactive power / active power % of 3 phase system.

### 5.2 User Menu

Main Menu

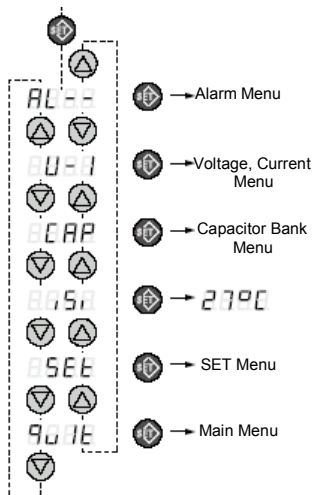

To access the User Menu, press down the Set button for a short time in Main Menu. Direction Buttons are used to move in the menu in desired direction. To enter any sub-menu, use the Set Button. To change any parameter value while the name and the value is flashing on the screen, press the Set button. Adjust the value using the direction buttons and press again the Set button to store the value. To quit from sub-menus and User Menu, advance to 'quit' section at the end of the menu and press Set button on it.

In User Menu, alarms (if exists any at that time), voltage and current values of each phase, capacitor bank powers and panel temperature are tracked. Also some set parameters can also be accessed under this menu. The contents of sub-menus and accessing them is described below.

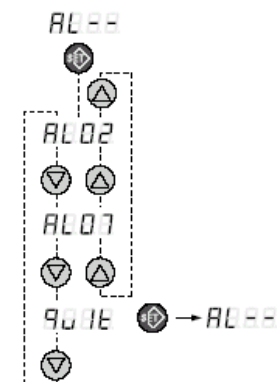

#### Alarm Menu

► **AL --** : This menu is displayed only when at least one alarm is present, otherwise it is disabled. The alarm codes of present alarms are monitored under this menu. It is accessed by pressing the Set button. Alarm codes can be monitored using the direction buttons, if are there any other. It can be quited from the menu by pressing the Set button on 'quit' section. **When all alarm conditions are disappeared, device automatically quits this menu.** Alarm codes and detailed information can be found in ALARMS section.

**Voltage, Current Menu**

► **U-I** : Phase-neutral voltages and currents of each phase can be monitored here. This section is accessed by pressing the Set button. Direction buttons are used to advance in desired direction. Phase R voltage, Phase S voltage, Phase T voltage and Phase R current, Phase S current, Phase T current are monitored sequentially. When Set button is pressed at the 'quit' section, one level up menu is accessed. To monitor current values correctly, current transformer ratio must be set in the Advanced Menu.

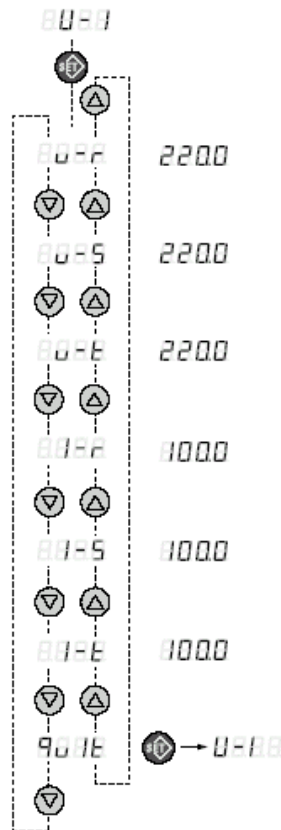

**Capacitor Bank Menu**

► **CAP** : Current transformer ratio and capacitor bank powers can be displayed separately. This section is accessed pressing the Set button. The current transformer ratio is the first parameter of this menu. Direction buttons are used to move in the desired direction. From 1<sup>st</sup> to the last bank power are monitored in this menu in KVAR unit. When Set button is pressed at the 'quit' section, one level up menu is accessed.

**This values are changed in Advanced Menu.**

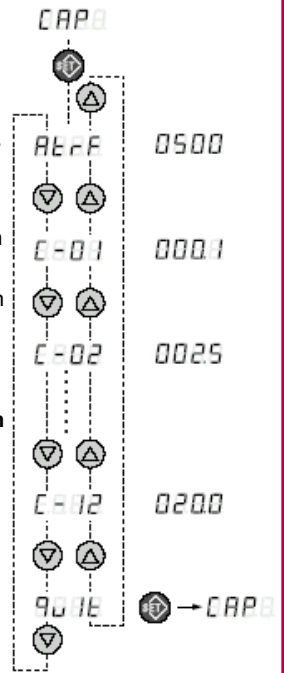

**Temperature Display Menu**

► **ISI** : The temperature (°C) inside the device housing is monitored here. Please keep in mind that, the displayed value may be 5-10 (°C) higher than inner panel temperature. Temperature alarm and fan set values can be changed under advanced value.

**Set Menu**

► **SEt** : The parameters to be set are under this menu. Desired parameter can be accessed by using the direction buttons. On the display, parameter name and numerical value are shown by interchanging. To change the parameter values, press the set button, using the direction buttons reach the desired value. By pressing down the set button, displayed value is stored and the menu is directed to interchange screen. To quit from set menu, advance to 'quit' section and press Set button on it.

**COSF:**

It is the section that Cosφ value is set in the range of 0.80 inductive – 1.00. **tCon** : (Max. capacitor bank switch on time) It can be adjusted in the range of 10-60 secs.

**tCOF** : (Max. capacitor bank switch off time) It can be adjusted in the range of 10-60 secs. Device calculates the necessary tCON/tCOFF time in the range of tAlt and set value, according to total consumption. Thus, when not necessary, capacitor banks are not switched fast and when necessary faster compensation is achieved automatically.

(Min. value of capacitor bank switch on&off times) It can be adjusted in the range of 2-10 s.

**tAlt** : (Min. value of capacitor bank switch on&off times) It can be adjusted in the range of 2-10 s.

**StIL** : (Working mode selection) mod01, mod02 and mod03 is used to restrict the operating modes of the device. If mod01 is chosen, device operates only in this mode. If mod02 is chosen, the device operates in mod01 or mod02. If mod03 is chosen, device may choose appropriate mode. Ideally, it is advised to choose mod03.

**qUlt** : Pressing down the set button, the one level up menu section is reached.

► **qUlt** : Pressing down the set button, device returns to main menu.

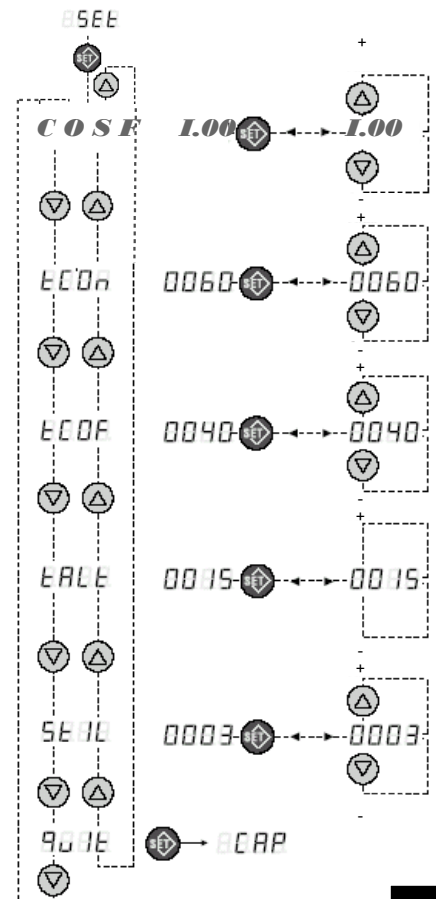

5.3 ADVANCED MENU

It is the section that important and critical settings of the device can be done. To avoid accidental access to this menu, it is accessed by energizing the device while hold down the set button. It is important to hold down the button when the device is de-energised and energize it while the button is pressed and keep it pressed till the 'AdU' appears on the screen. Using the direction keys, can be advanced in the desired direction. To enter any section, just press set button on it. When set button is pressed on the 'quit' section, device resets itself and starts in normal mode. Also, when no key is pressed for 4 minutes, device resets itself. In both cases, before reset, device stores the changes in its memory.

when the device is de-energised and energize it while the button is pressed and keep it pressed till the 'AdU' appears on the screen.

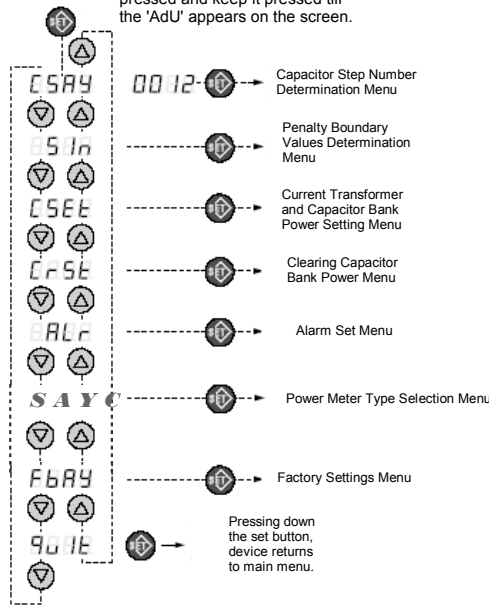

Capacitor Step Number Determination Menu

► CSAY :

It is the section that used to set used capacitor step number. Capacitor step number is set in the range of 3-8/12. Parameter name and capacitor step number are shown by interchanging on the screen.

It is advised to set the capacitor step number to the value that you wish to use.



Penalty Boundary Values Determination Menu

► SIn :

It is the section that penalty boundary values are adjusted in terms of (reactive energy / active energy) %. It is accessed by pressing the set button. Inductive boundary (CZ-E) and capacitive boundary (CZ-C) are accessed by direction keys. Pressing down the set button, the one level up menu section is reached. Please do not set boundary values to higher values than the limits of your power distributor firm.

**CZ-E** : It is the section that inductive penalty value is set as %. It is accessed by pressing the set button, the value is adjusted by using the direction buttons and it is stored by pressing the set button again. It can be set in the range of 10% - 50% (reactive energy / active energy). If inductive % is close to penalty limit, inductive value can be set to a lower value from here.

**CZ-C** : It is the section that capacitive penalty value is set as %. It is accessed by pressing the set button, the value is adjusted by using the direction buttons and it is stored by pressing the set button again. It can be set in the range of 5% - 50% (reactive energy / active energy). If capacitive % is close to penalty limit, capacitive value can be set to a lower value from here.

**quit** : Pressing down the set button, device returns to main menu.

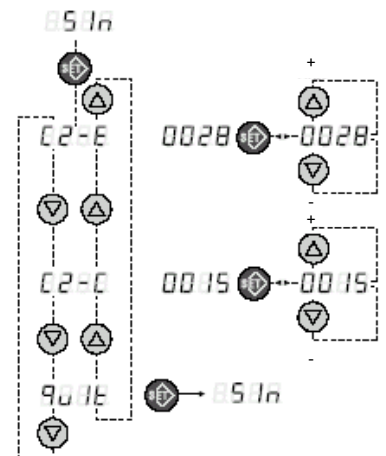

Current Transformer and Capacitor Bank Power Setting Menu

► CSEt : It is the section that current transformer ratio and capacitor bank powers are set. It is accessed by pressing the set button. Using the direction keys, it can be advanced in the desired direction. At quit section, pressing down the set button, the one level up menu section is reached.

**AtrF** : When current transformer ratio is expressed as x/5, the 'X' value is displayed on the screen and this value is adjusted in the range of 5-10000 by steps of 5. It is accessed by pressing the set button and the value is adjusted using the direction buttons. It is stored by pressing the set button again. Setting this parameter is not necessary for compensation. If you wish to see current values in terms of primer values or want to set capacitor bank powers manually, current transformer value **absolutely** set.

*Keeping the direction button pressed down increases advance speed.*

**C-XX** : It is the section that capacitor bank powers are set in KVAR unit. It can be set in the range of 0-current transformer ratio by steps of 0.1 KVAR. It is accessed by pressing the set button and the value is adjusted using the direction buttons. It is stored by pressing the set button again. Before making this adjustment, current transformer ratio **must** be set.

*Keeping the direction button pressed down increases advance speed.*

Remarks

- 1- Even if capacitor bank powers are not manually set, device learns these values by its own. This may take some time but compensation is continued during learning.
- 2- In case of setting capacitor bank powers, device directly jumps to mod03 without any time lose.
- 3- In case of any wrong value setting, device learns the correct value as it operates and overwrites the user set value.

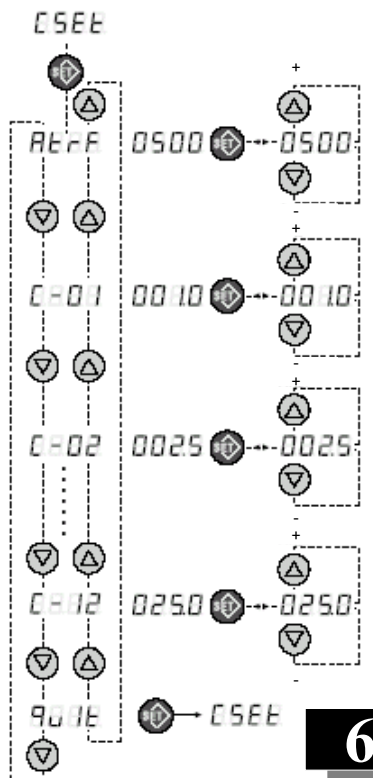

### Clearing Capacitor Bank Power Menu

► **CrSt :**

It is the section that capacitor bank powers in device memory are cleared all together or separately.

**CALL :** It is the section that all capacitor bank powers are reset all together. After this operation, all stored bank powers are cleared and learned again during bank switchings. Operation is approved by pressing the set button. After the process is accomplished, device jumps to quit section at the end of the menu.

*Rem:* When device is connected to another panel or when most of the bank powers are changed, it is advised to reset all bank powers.

**C-XX :** Related bank power is cleared from device memory. During its operation, this bank power is learned again. The operation is approved by pressing the set button. After the process is accomplished, power value is displayed as 0. At the quit section, end of the menu, pressing down the set button, the one level up menu section is reached.

*Rem:* When a capacitor bank is changed, it is advised to make reset related bank power. It is not obligated because device keeps learning bank powers during operation.

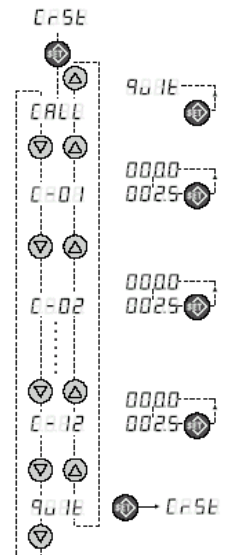

### Alarm Set Menu

► **ALr :** It is the section to

enable-disable the alarms of device and setting alarm values. It is accessed by pressing the set button. Using the direction buttons can be advanced in desired direction. To quit, advance to 'quit' section at the end of the menu and press Set button to jump one level up.

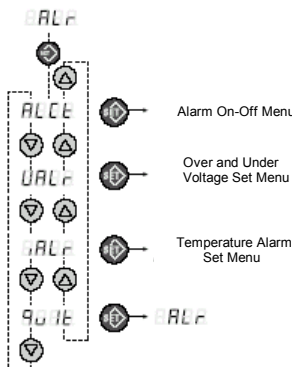

### Over and Under Voltage Set Menu

► **UALr :** It is the section that over and under voltage alarm limits are adjusted and Capacitor Save mode is disabled/enabled. It is accessed by pressing the set button and using the direction buttons can be advanced in desired direction. To quit, advance to 'quit' section at the end of the menu and press Set button to jump one level up.

**UUST :** It is the section that over voltage alarm limit is adjusted. The value can be set in the range of 230 V – 270 V by steps of 1V. It is accessed by pressing the set button and using the direction buttons can be advanced in desired direction. Press set button to store new value and quit.

*Please be sure that this alarm is enabled in ALCT section. Otherwise, these limits are meaningless.*

**UALt :** It is the section that under voltage alarm limit is adjusted. The value can be set in the range of 170 V – 210 V by steps of 1V. It is accessed by pressing the set button and using the direction buttons can be advanced in desired direction. Press set button to store new value and quit.

*Please be sure that this alarm is enabled in ALCT section. Otherwise, these limits are meaningless.*

**C-SU :** It is the place that Capacitor Save mode is disabled/enabled.

If capacitor save is enabled, in case of under/over voltage or missing phase alarms, all capacitor banks are switched of sequentially to protect them. It is accessed by pressing the set button, On or Off state is displayed on the screen. To enable capacitor save, select On and to disable it select Off. Press set button to store the change.

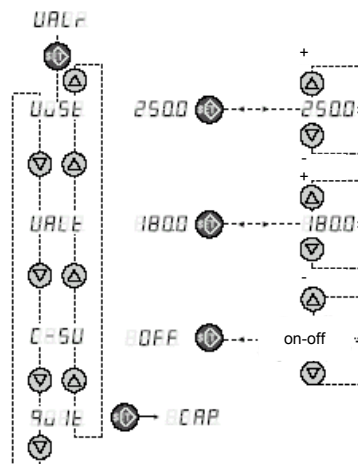

### Alarm On-Off Menu

► **ALCT :** It is the section that all 9 alarms of the device are enabled/disabled all together or separately. It is accessed by pressing the set button. Using the direction buttons can be advanced in the desired direction. To quit, advance to 'quit' section at the end of the menu and press Set button to jump one level up.

**AALr :** It is the section that all 9 alarms of the device are enabled/disabled all together. For each alarm, alarm enable state is displayed as On or Off. To enable select On and to disable select Off and to store the change press set button. If you disabled all alarms, separate control menus of alarms will disappear automatically.

**AL-XX :** It is the section that related alarm is disabled/enabled. For more detailed information about alarms, please refer to Alarms section. It is accessed by pressing the set button, On or Off state is displayed on the screen. To enable the related alarm, select On and to disable it select Off. Pressing the set button, store the change. *If you cannot see this section, probably all alarms are disable in AALr section. First enable them all.*

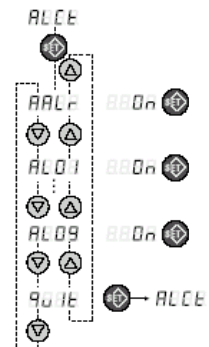

### Temperature Alarm Set Menu

► **IAIr** : It is the section that Temperature Alarm, Fan Temperature and Fan enable/disable state are set. It is accessed by pressing the set button and using the direction buttons can be advanced in desired direction. Press set button at quit section to jump one level up.

**IUSt** : It is the section that Temperature Alarm value is set. It is adjusted in the range of (Fan temperature limit + 5C) – 80C by steps of 1C. It is accessed by pressing the set button and using the direction buttons can be advanced in desired direction. Press set button to store new value and quit. *Please be sure that this alarm is enabled in ALcT section. Otherwise, these limits are meaningless.*

**Fan** : It is the section that Fan enable/disable state is set in case of exceeding set fan value. It is accessed by pressing the set button and On / Off state is displayed. To enable fan operation when necessary select On and to disable it select Off by direction buttons. Press set button to store change and quit.

**IFan** : It is the section that fan operation temperature limit is set. It is adjusted in the range of 25C – (temperature alarm value(iuSt) -5C) by steps of 1C. It is accessed by pressing the set button, the value is adjusted by direction buttons and set by pressing the set button. *Please be sure that fan operation when necessary is enabled in Fan section, otherwise this temperature setting is meaningless.*

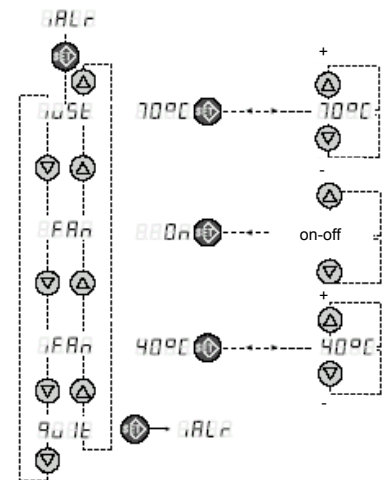

### Power Meter Type Selection Menu:

#### ► SAYC :

It is the section that power meter type is selected. Either vectorial resultant sum (mechanical meter) mode or arithmetical separate inductive and capacitive energy storing (electronics meter) mode can be selected. For mechanical meters 'nor' and for electronics meters 'ELEC' is displayed.

### Factory Settings Menu

► **FbaY** : It sets back all user settable parameters to factory defaults. On this section, by pressing the set button, stored values are set back to factory defaults and device turns off itself. To restart the device, please de-energize it and re-energize again.

If you think that device parameters are changed incorrectly and you have difficulty to change them back to original values, you can reset them to factory defaults by using this property.

Factory Defaults are;

- Capacitor bank step number for VARko-312 is 12, for VARko-308 is 8
- Inductive penalty limit value (CZ-E) 30%
- Capacitive penalty limit value (CZ-C) 15%
- Capacitor bank switch-on time max. value 15s
- Capacitor bank switch-off time max. value 10s
- Capacitor bank switch-on&off time min. value 5s
- Over voltage alarm set value (UUSSt) 250V
- Under voltage alarm set value (UAlt) 190V
- Capacitor save mode (C-SU) OFF (no protection)
- Fan enable when necessary (Fan) On (Fan output is active)
- Temperature alarm value (IUSt) 70C
- Fan on temperature (Ifan) 45C
- Current transformer ratio 5/5
- Mod03
- All capacitor bank powers are reset to zero

## 6. ALARMS

To fully control compensation system, to be aware of present problems, to investigate the reasons and overcome these problems, handy and settable alarms are necessary. On the other hand, to be able to disable these alarms when necessary will prevent to panic user. VARko-3xx has the all the alarms necessary for a compensation system and more. Thus, system tracking by technical staff and diagnosis of faults become easier. Below, you will find explanations about the alarms of the device. To obtain more information about alarms, please refer to Alarm Set Menu section under Advanced Menu. When an alarm condition occurs, alarm code can be monitored under User Menu → ALr section. For further information about this topic, please refer to User Menu section.

When any alarm occurs related to a problem, both alarm LED and relay are energized together. Alarm LED is kept on as long as the alarm condition is continuous, however, alarm relay is de-energized after 1 minutes. Thus, until the technical staff resolves the problem, people around are not disturbed. *When the horn connected to alarm relay is silent, this does not indicated that the problem is disappeared. To understand it alarm LED must be tracked. When alarm situation is continuous please call technical staff. An alarm may have more than one reasons. Therefore, when investigating the reasons of an alarm, you do not have to stop it after finding one reason.*

**AL01** : Over Voltage (230V – 270V adjustment range)

If voltage value of any phase exceeds alarm set limit value and this situation continues 5s, alarm LED is turned on and alarm relay is energized. When phase voltages goes 5V below to set limit at least 5s, alarm situation is cleared. If "C-SU" is chosen as On, in over voltage case, banks are switched off sequentially. If it is OFF, compensation is continued. Factory default value is "OFF".

**AL02 : Under Voltage (170V – 210V adjustment range)**

If voltage value of any phase goes below alarm set limit value and this situation continues 5s, alarm LED is turned on and alarm relay is energized. When phase voltages goes 5V above to set limit at least 5s, alarm situation is cleared. If "C-SU" is chosen as On, in under voltage case, banks are switched off sequentially. If it is OFF, compensation is continued. Factory default value is "OFF".

**AL03 : Over Current(secondary current >8A, constant boundary)**

When any of the secondary currents of transformers connected to phases exceed 8A for at least 60s, alarm LED is turned on and alarm relay is energized. If current value goes below 8A at least for 60s, alarm situation is cleared.

**Reason:** Current transformer is not proper for the system. A higher rate must be preferred.

**Solution:** Appropriate value must be found by measuring the phase currents and current transformers must be changed with that value.

**AL04 : Over Compensation**

When system's over all compensation percentage exceeds set capacitive limit, alarm LED is turned on and alarm relay is energized. Until it goes below this limit, alarm condition is continued.

**Reason:** Capacitor bank powers are chosen to big or improper bank power selection.

**Solution:** Capacitor bank number must be increased and necessary bank powers must be recalculated & increased. Load must be equally distributed to each phase and the system must be made as balanced as possible. Capacitor switch-off time must be decreased.

**AL05 : Under Compensation**

When system's over all compensation percentage exceeds set inductive limit, alarm LED is turned on and alarm relay is energized. Until it goes below this limit, alarm condition is continued.

**Reason:** Capacitor bank powers are chosen to small or improper bank power selection.

**Solution:** Necessary bank powers must be recalculated and increased. Load must be equally distributed to each phase and the system must be made as balanced as possible. Capacitor switch-off time must be decreased.

**AL06 : System Fault**

When all capacitor bank powers are measured as 0 KVar, this alarm is generated.

**Reason:**

1. Capacitor banks may be connected before the current transformers,
2. Capacitor bank switches may be off
3. Contactor inductance supplies may be off
4. Contact phase (line) may not be connected to device

**Solutions:**

1. Place capacitor bank connections after current transformers,
2. Check capacitors banks' switches
3. Check contact line connection and contact outputs of devices
4. After all controls, de-energize and re-energize the devices

**AL07 : Capacitor Bank Fault**

When device measures the unbalance of a capacitor bank between its powers on each phase, this alarm is generated.

**Reason:**

1. At least one of the connections of one capacitor bank is connected before the current transformer
2. At least one of the switches on any phase of a capacitor bank may be off
3. At least one contact of contactor may be disconnected
4. Capacitor bank may be death

**Solutions:**

1. Check capacitor bank's switches
2. Check device's phase connections
3. Change the capacitor bank
4. After all controls, de-energize and re-energize the devices

**AL08 : Missing Phase**

If at least one of the phases is missing, alarm LED is turned on and alarm relay is energized. If capacitor save mode (C-SU) is on, compensation is stopped and banks are switched off. Otherwise compensation continues. Factory default of C-SU is off.

**AL09 : Over Temperature (Fan Limit + 5°C – 80°C range)**

When inner panel temperature exceeds set alarm value, alarm LED is on and alarm relay is energized. When temperature goes 2°C below to set value, alarm condition is cleared. Fan relay output of device is different and its set value is adjusted separately. When setting temperature value, please keep in mind that, device temperature is 5-10°C higher than panel temperature.

**Fan Relay Output: (25°C – Fan limit-5°C)**

VARko-3xx gives the user opportunity of tracking and controlling the temperature. When temperature exceeds set fan value, fan relay is energized. If you connect this output to a fan, the panel may be cooled before its temperature reaches to critical limit. If the temperature continues to increase, over temperature alarm is generated and user is warned. The device will let you to adjust Fan temperature value at least 5°C less than temperature alarm value. For example, if over temperature alarm value is 55°C, fan value may be max. 50°C.

## 7. COMMISSIONING THE SYSTEM

- Please read warnings and cautions in section 2 of this user's manual
- Please be sure that the electric panel being used is de-energized
- Please be sure that compensation panel is supply voltages are taken after the current transformers in main panel
- Please be sure that current, voltage and contact outputs are connected exactly as shown in the connection diagram
- Switch on the switches of capacitor banks
- Energize the compensation system. If you see Err1 or Err2 message on the screen, immediately contact with KAEL Elektronik Ltd. Please.
- VARko-3xx will immediately start to compensation depending on the consumed power. If there is no current is drawn from the system, device will wait until any current is drawn. In this case, you may consider it as a good test opportunity and test your system in mod00 (manual mode) by switching all capacitor banks on and off.
- If you choose current transformer ratio and capacitor bank power appropriately, in most of the cases you do not need to change any setting of the device.
- Please be sure that alarm LED is off. Otherwise, investigate the reason of alarm and solve the problem.

## 8. Connection Diagram

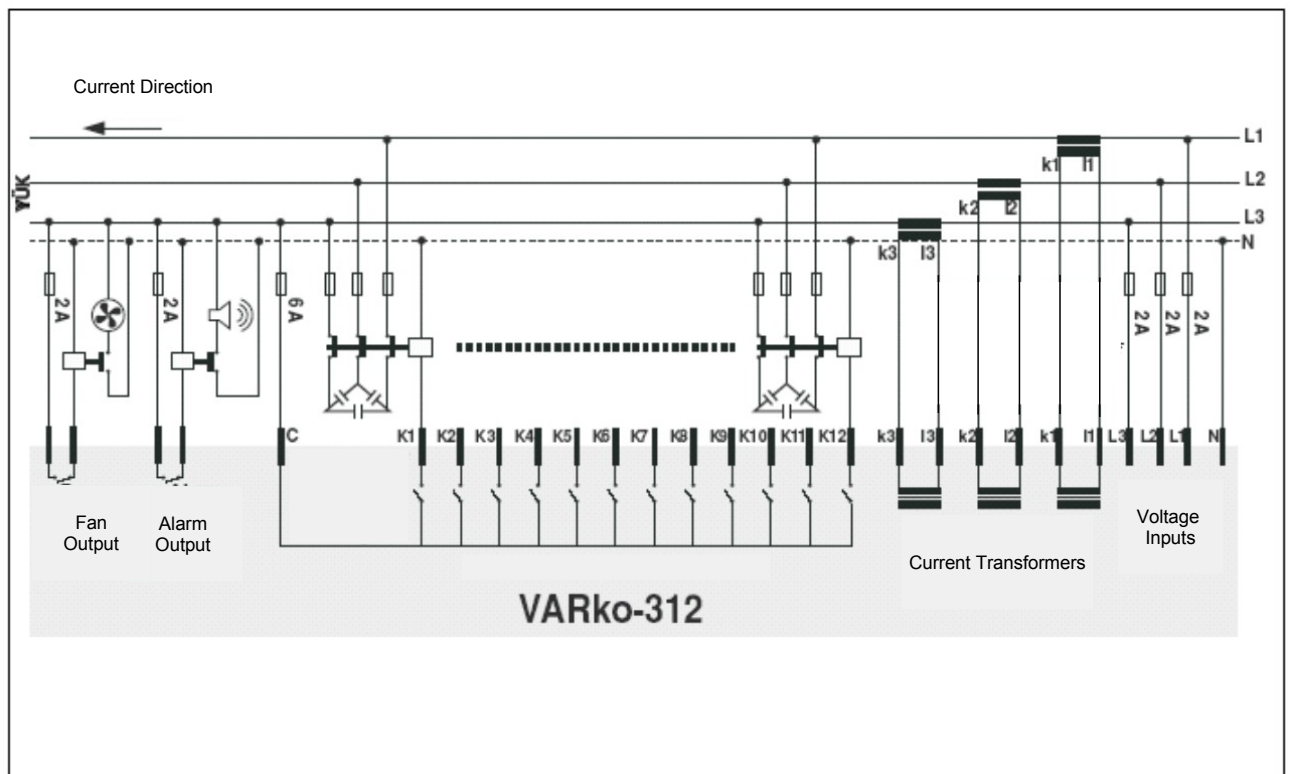

The fuses shown in the connection diagram must be FF type and must have specified current values. Chosen current transformers' real value must not be less than drawn current and they must be X/5 Amps. It must be stated on the switches that are connected to supply voltage lines of the device that they will be used to disconnect the device from the power line. Before making the connections, the warnings and cautions in section 2 must be read.

## 10. TECHNICAL DATA

Rated Voltage(Un)	: (Phase-Neutral) 220VAC, (Phase-Phase) 380 VAC
Operating Range	: (0.8 – 1.1) x Un
Operating Frequency	: 50 Hz
Power Consumption	: < 10 VA
Measurement Inputs	
Power Consumption	: < 1 VA
Contact Current	: Max. 3 A /240 VAC
Current Measurement Range	: (As secondary current of Curr. Trf.) 0.1-6 Amp AC
Display Range	: (Power Factor) 0.00 – 1.00 Ind.&Cap.
Min. Current Measurement Value	: 50 mA
Measurement Sensitivity	: 1%+- digit
Current Transformer Ratio	: 5/5 .... 10000/5 A
Max. Cap. Bank	
Switch On&Off Time	: 10.... 60 s
Min. Cap. Bank	
Switch On&Off Time	: 2.... 10s
Ind% Set Value	: 10%... 50% (Factory set value=30%)
Cap% Set Value	: 5%... 50% (Factory set value=15%)
Display	: 4 Digits LED Display

Protection Class	: IP 20
Connector Protection Class	: IP 00
Ambient Temperature	: -5°C...+50°C
Humidity	: 15%...95%
Connection Type	: To front panel tap
Dimensions	: 144x144x40 mm

