

PFR-3 , PFR-2 , PFR-1

POWER FACTOR REGULATOR

- ▶ Adjustable Target Cos ϕ (0,70 – 1,00)
- ▶ C/k (0,05 – 2)
- ▶ Switch on Time - Ton (1 – 100 s)
- ▶ Switch off Time - Toff (1 – 100 s)
- ▶ PFR-3 3 steps
- ▶ PFR-2 2 steps
- ▶ PFR-1 1 step

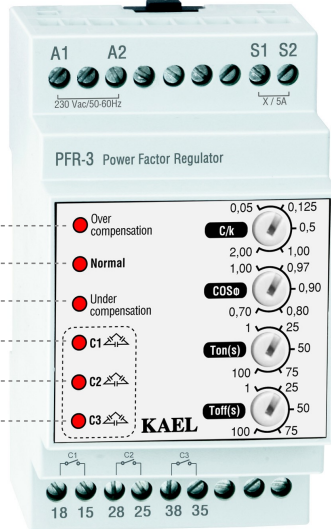

Connection:

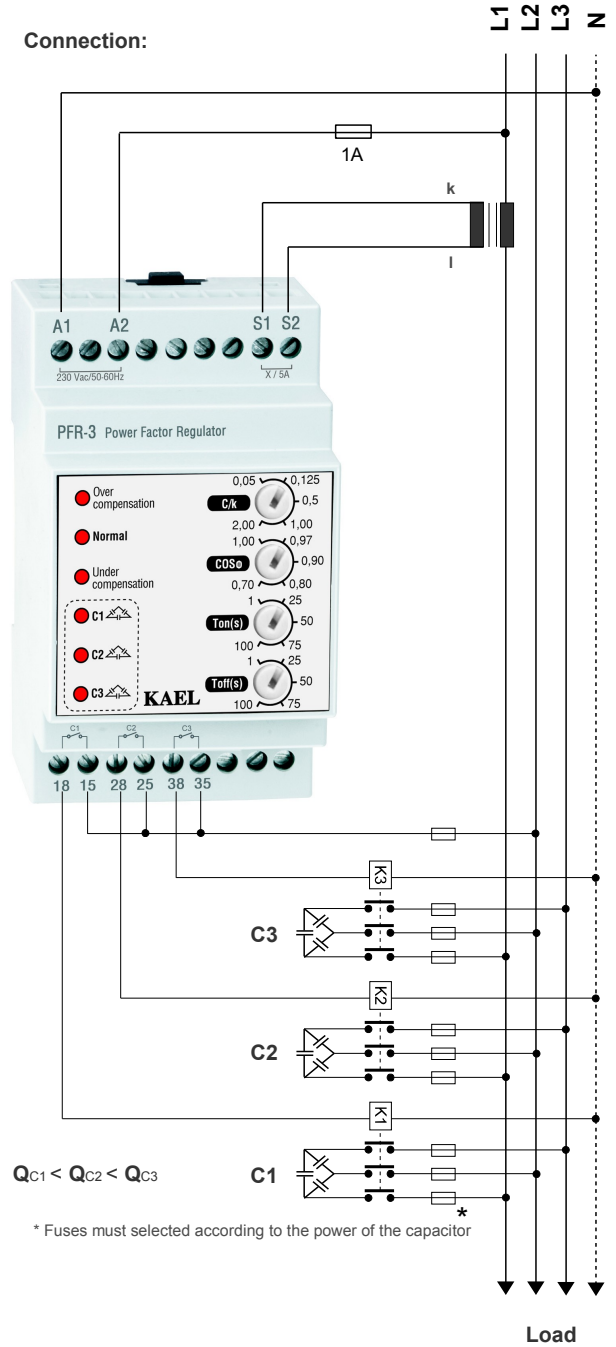

NOTE: $Q_{C1} < Q_{C2} < Q_{C3}$

* Fuses must selected according to the power of the capacitor

- Over Compensation
- Normal
- Under Compensation
- 1. Step
- 2. Step
- 3. Step

GENERAL:

it is used to work with a fixed load or for local compensation. Especially can be used for submersible pump compensation. Does not occupy a place within the panel, it is economical and it is very easy to use. The power value of the 1st step capacitor has to be the smallest between others.

$$Q_{C1} < Q_{C2} < Q_{C3}$$

ADJUSTMENT:

C/k : (0,05 – 2)

C: Power of first capacitor.
k : Current transformer ratio.

Example:

If C: 1 KVAR
and k: 50/5 A
In this case;
 $k=50/5 = 10$ and $C/k= 1/10= 0,1$
Adjust C/k to 0,1

Target Cos ϕ : (0,70 – 1,00)

Ton : (1 – 100 s) Switch on time.

Toff : (1 – 100 s) Switch off time.

Installation Instruction :



- Read the user instructions and caution before installation.
- Be sure that the panel you are installing in when power off.
- The device designed to be installed to the rail where the installation tap into the panel,
- Do not under case open the front of device.
- You should open the Terminals at the back side of the device after you must be sure that there is no power in the panel. Connect the device as shown in the connection scheme.
- Do not use current transformer less than nominal current
- Please use fast type fuse to protect the device's power supply input
- Clean the device using dry dust cloth after turned off device.
- Read and follow the instruction on this manual and attached label.

TECHNICAL INFORMATION:

Rated Voltage (Un)	: 230Vac (L1-N)
Operating Range	: (0,8-1,1) x Un
Operating Frequency	: 50 / 60 Hz
Supply Power Consumption	: < 4VA
Current Measurement Range	: 0,05 - 6 A
Current Transformer Ratio	: X / 5 Amper
Inputs Power Consumption	: <1VA
Contact Current	: Max. 3A / 240Vac
Device Protection Class	: IP 20
Connector Protection Class	: IP 00
Temperature	: - 5 °C + 50 °C
Connection Type	: To connection rail in electrical panel
Dimension	

